



CITEL

Surge protector for LED lighting system Class 1

MLP2-230L-W-2L



Specially developed spd with combined protection for 2-phase power supply (control phase):

- Many variants available depending on application
- With screw terminals or cable wiring
- IP65 versions
- For protection class I or II application
- Developed for Uoc: 10 kV and I_{max}: 10 kA for highest outdoor requirements according to IEEE & ANSI
- Optical error signalling

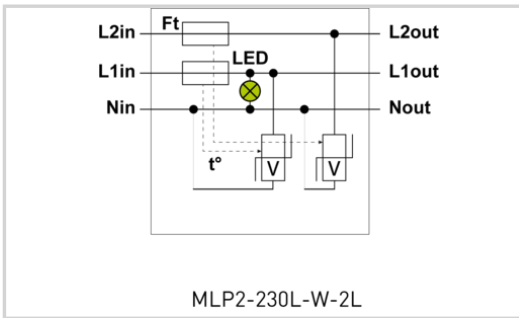

Electrical Characteristics		
SPD type		2+3
AC system		TT-TN
Nominal line voltage	Un	230-277 Vac
Max. AC operating voltage	Uc	305 Vac
Max. frequency	f max.	10 MHz
Max. load current @25°C	IL	2.5 A
Temporary Over Voltage (TOV) Characteristics - 5 sec. Without disconnection	UT	335 Vac withstand
Temporary Over Voltage (TOV) Characteristics - 120 mn Without disconnection or with safety disconnection	UT	440 Vac disconnection
Residual Current Leakage current to Ground	I _{pe}	None
Follow current	I _f	None
Nominal discharge current 15 x 8/20 μs impulses	I _n	5 kA
Max. discharge current max. withstand @ 8/20 μs by pole	I _{max}	10 kA
Total Maximum discharge current max. total withstand @ 8/20 μs	I _{max} Total	20 kA
Withstand on Combination waveform IEC 61643-11 Class III test: 1.2/50μs - 8/20μs	Uoc	10 kV / 5 kA
Withstand on overvoltages IEEE C62.41.1		10 kV / 10 kA
Protection level L/N @ I _n (8/20μs)	U _p L/N	1.5 kV
Protection level L/PE @ I _n (8/20μs)	U _p L/PE	1.5 kV
Admissible short-circuit current	I _{sc}	10 000 A
Mechanical Characteristics		
Mounting		Wall or plate
Housing material		Thermoplastic UL94 V-0
Operating temperature	Tu	-40/+85°C
Dimensions		See diagram
Disconnectors		
Thermal disconnector		Internal
Installation ground fault breaker		Type 'S' or delayed
Standards		
Standards compliance		IEC 61643-11 / EN 61643-11 / UL1449 ed.5
Part number		
731212		

