



# AC surge protector for LED Lighting system Class 1

# CITEL

## MLPC1-230L-V/50



- Type 2 (or 3) surge protectors for LED
- Class 1
- Very compact
- Plate mounting
- Screw terminal connection
- Status indicator
- Disconnection AC end of life
- EN 61643-11 compliance

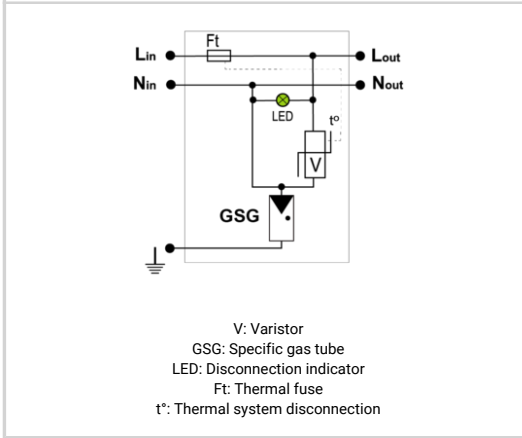
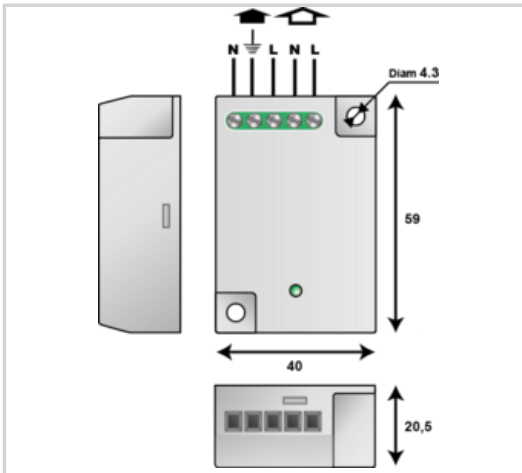

Electrical Characteristics	
SPD type	2 (or 3)
Network	220-240 V Single-phase
AC system	TT-TN
Max. AC operating voltage	Uc 320 Vac
Max. load current @25°C	IL 5 A
Temporary Over Voltage (TOV) Characteristics - 5 sec. Without disconnection	UT 335 Vac withstand
Temporary Over Voltage (TOV) Characteristics - 120 mn Without disconnection or with safety disconnection	UT 440 Vac disconnection
Temporary Over Voltage N/PE (TOV HT) Without disconnection or with safety disconnection	UT 1200 V/300A/200 ms disconnection
Residual Current Leakage current to Ground	Ipe None
Nominal discharge current 15 x 8/20 μs impulses	In 5 kA
Max. discharge current max. withstand @ 8/20 μs by pole	I <sub>max</sub> 10 kA
Total Maximum discharge current max. total withstand @ 8/20 μs	I <sub>max</sub> Total 20 kA
Withstand on Combination waveform IEC 61643-11 Class III test: 1.2/50μs - 8/20μs	Uoc 10 kV
Withstand on overvoltages IEEE C62.41.1	10 kV / 10 kA
Protection mode(s)	Common/Differential mode
Protection level L/N @ In (8/20μs)	Up L/N 1.5 kV
Protection level L/PE @ In (8/20μs)	Up L/PE 1.5 kV
Admissible short-circuit current	I <sub>sc</sub> 10 000 A
Mechanical Characteristics	
Technology	MOV+GDT
Connection to Network	1 screw contact single side in/out - wire 2.5mm <sup>2</sup> max.
Mounting	On plate
Housing material	Thermoplastic UL94 V-0
Operating temperature	Tu -40/+85°C
Protection rating	IP20
Failsafe mode	Disconnection and AC line cut-off
Disconnection indicator	LED green OFF and AC network cut-off
Voltage/operating indicator	Green Led ON
Dimensions	See diagram
Weight	0.038 kg
Disconnectors	
Thermal disconnector	Internal
Installation ground fault breaker	Type 'S' or delayed
Standards	
Standards compliance	EN 61643-11 / IEC 61643-11
Certification	/ TÜV / IMQ / ROHS
Part number	
831222	

