



Type 2+3 AC surge protector - single-phase

CITEL

DS42VGS-230



- Type 2 + 3 AC Multipolar surge protector
- In : 20 kA
- I_{max} total: 80 kA
- Pluggable module
- Follow and operating current : none
- No ageing
- remote signaling state
- Optimized to TOV
- EN 61643-11, IEC 61643-11, UL1449 ed.5 compliance

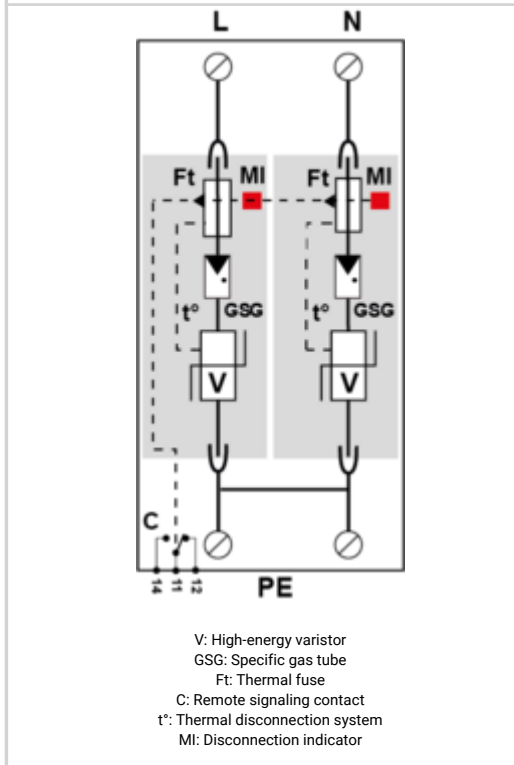
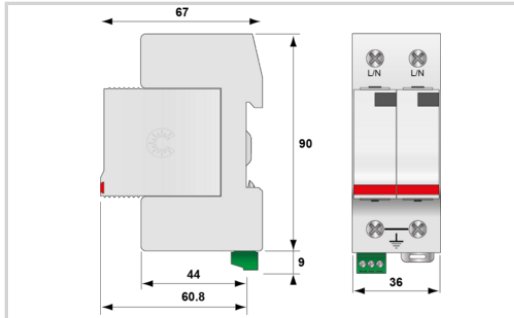

Electrical Characteristics	
SPD type	2+3
Network	230 V single-phase
AC system	TN
Nominal line voltage	Un 230 Vac
Max. AC operating voltage	Uc 255 Vac
Temporary Over Voltage (TOV) Characteristics - 5 sec. Without disconnection	UT 335 Vac withstand
Temporary Over Voltage (TOV) Characteristics - 120 mn Without disconnection or with safety disconnection	UT 440 Vac withstand
Residual Current Leakage current to Ground	I _{pe} None
Follow current	I _f None
Nominal discharge current 15 x 8/20 μs impulses	I _n 20 kA
Max. discharge current max. withstand @ 8/20 μs by pole	I _{max} 40 kA
Total Maximum discharge current max. total withstand @ 8/20 μs	I _{max} Total 80 kA
Withstand on Combination waveform IEC 61643-11 Class III test: 1.2/50μs - 8/20μs	U _{oc} 6 kV
Withstand on overvoltages IEEE C62.41.1	20 kV
Connection mode(s)	L/PE and N/PE
Protection mode(s)	Common mode
Residual voltage @ I _n (8/20 μs)	U _{p-in} 0.8 kV
Protection level L/PE @ I _n (8/20μs)	U _p L/PE 1.25 kV
Admissible short-circuit current	I _{sc} 25 000 A
Mechanical Characteristics	
Technology	VG Technology (MOV+GSG)
SPD configuration	Single phase
Connection to Network	By screw terminals: 2.5-25mm ² / by bus
Format	Plug-in modular box
Mounting	Symmetrical rail 35 mm (EN 60715)
Housing material	Thermoplastic UL94 V-0
Operating temperature	T _u -40/+85°C
Protection rating	IP20
Failsafe mode	Disconnection from AC network
Disconnection indicator	1 mechanical indicator by pole
Spare module(s)	DSM40VG-230
Remote signaling of disconnection	Output on changeover contact
Dimensions	See diagram
Weight	0.19 kg
Disconnectors	
Thermal disconnector	Internal
Installation ground fault breaker	Type 'S' or delayed
Back-up protection device	50 A min. - 125 A max. - Fuses Type gG
Standards	
Standards compliance	IEC 61643-11 / EN 61643-11 / UL1449 ed.5
Certification	UL Recognized
Part number	
461571	

