



CITEL

Surge protector for LED lighting system Class 1

MLP1-230L-W



Specially developed spd with combined protection for 2-phase power supply (control phase):

- Many variants available depending on application
- With screw terminals or cable wiring
- IP65 versions
- For protection class I or II application
- Developed for Uoc: 10 kV and I_{max}: 10 kA for highest outdoor requirements according to IEEE & ANSI
- Optical error signalling

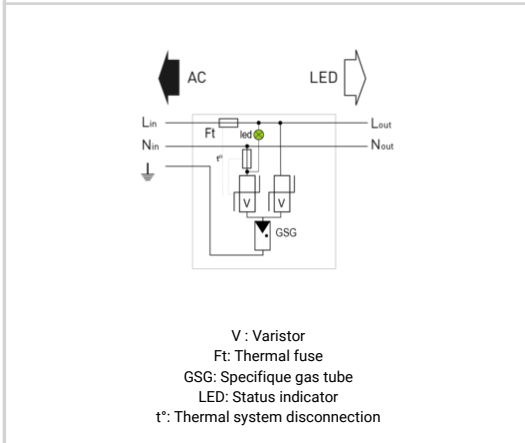
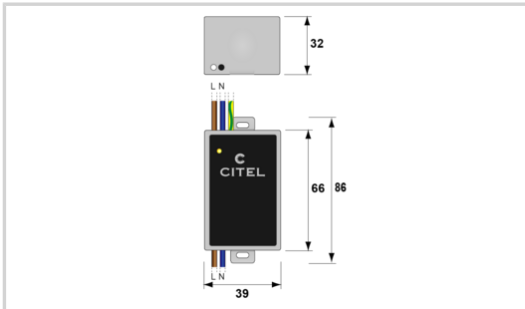

Electrical Characteristics	
SPD type	2+3
Network	220-240 V Single-phase
AC system	TT-TN
Nominal line voltage	U _n 230-277 Vac
Max. AC operating voltage	U _c 305 Vac
Max. frequency	f max. 10 MHz
Max. load current @25°C	I _L 2.5 A
Temporary Over Voltage (TOV) Characteristics - 5 sec. Without disconnection	UT 335 Vac withstand
Temporary Over Voltage (TOV) Characteristics - 120 mn Without disconnection or with safety disconnection	UT 440 Vac disconnection
Residual Current Leakage current to Ground	I _{pe} None
Follow current	I _f None
Nominal discharge current 15 x 8/20 μs impulses	I _n 5 kA
Max. discharge current max. withstand @ 8/20 μs by pole	I _{max} 10 kA
Total Maximum discharge current max. total withstand @ 8/20 μs	I _{max} Total 20 kA
Withstand on Combination waveform IEC 61643-11 Class III test: 1.2/50μs - 8/20μs	U _{oc} 10 kV / 5 kA
Withstand on overvoltages IEEE C62.41.1	10 kV / 10 kA
Protection mode(s)	Common/Differential mode
Protection level L/N @ I _n (8/20μs)	U _p L/N 1.5 kV
Protection level L/PE @ I _n (8/20μs)	U _p L/PE 1.5 kV
Admissible short-circuit current	I _{scr} 10 000 A
Mechanical Characteristics	
Technology	MOV+GDT
Connection to Network	By screw terminal: 1.5mm ² max.
Mounting	On plate
Housing material	Thermoplastic UL94 V-0
Operating temperature	T _u -40/+85°C
Protection rating	IP65
Failsafe mode	Disconnection and AC line cut-off
Disconnection indicator	LED green OFF and AC network cut-off
Voltage/operating indicator	Green Led ON
Remote signaling of disconnection	No
Dimensions	See diagram
Weight	0.109 kg
Disconnectors	
Thermal disconnector	Internal
Installation ground fault breaker	Type 'S' or delayed
Standards	
Standards compliance	IEC 61643-11 / EN 61643-11 / UL1449 ed.5
Part number	711211

