

MLPC2-230L-R

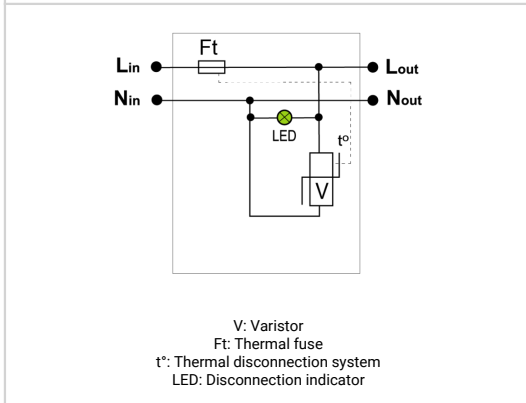

- ✦ Type 2 (or 3) surge protectors for LED
- ✦ Class 2
- ✦ Very compact
- ✦ Plate mounting
- ✦ Spring terminal connection
- ✦ Status indicator
- ✦ Disconnection AC end of life
- ✦ EN 61643-11 compliance

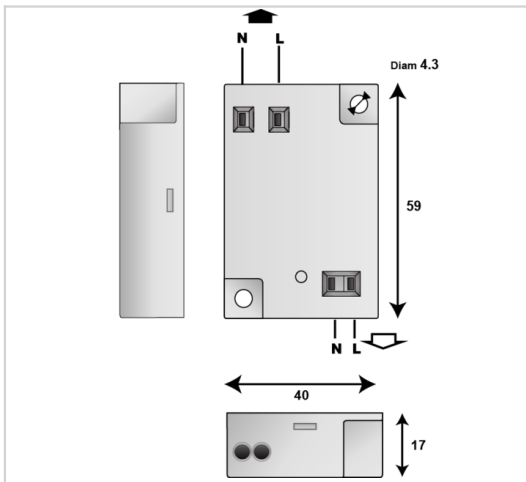

Electrical Characteristics		
SPD type	IEC	2 (or 3)
Network		230-277 V Single-phase
AC system		TT-TN
Max. AC operating voltage	Uc	320 Vac
Max. load current @25°C	IL	5 A
Temporary Over Voltage (TOV) Characteristics - 5 sec. Without disconnection	UT	335 Vac withstand
Temporary Over Voltage (TOV) Characteristics - 120 mn Without disconnection or with safety disconnection	UT	440 Vac disconnection
Residual Current		
Leakage current to Ground	Ipe	None
Nominal discharge current 15 x 8/20 µs impulses	In	5 kA
Max. discharge current max. withstand @ 8/20 µs by pole	Imax	10 kA
Total Maximum discharge current max. total withstand @ 8/20 µs	Imax Total	20 kA
Withstand on Combination waveform IEC 61643-11 Class III test: 1.2/50µs - 8/20µs	Uoc	10 kV
Withstand on overvoltages IEEE C62.41.1		10 kV / 10 kA
Protection mode(s)		Differential Mode
Protection level L/N @ In (8/20µs)	Up L/N	1.5 kV
Admissible short-circuit current	Iscrc	10 000 A
Mechanical Characteristics		
Technology		MOV+GDT
Connection to Network		2 spring terminals opposite side in/out - wire 1.5mm ² max.
Mounting		On plate
Housing material		Thermoplastic UL94 V-0
Operating temperature	Tu	-40/+85°C
Protection rating		IP20
Failsafe mode		Disconnection and AC line cut-off
Disconnection indicator		LED green OFF and AC network cut-off
Voltage/operating indicator		Green Led ON
Dimensions		See diagram
Weight		0.034 kg
Disconnectors		
Thermal disconnector		Internal
Installation ground fault breaker		Type 'S' or delayed
Standards		
Standards compliance		EN 61643-11 / IEC 61643-11
Certification		CB Tested / TUV / IMQ
Part number		
832211		