

MLPC2-277L-V

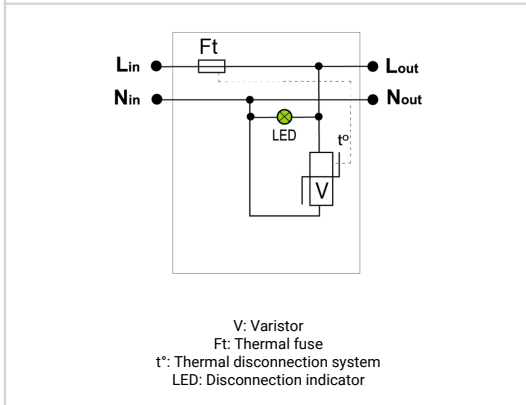

- ✦ Type 2 (or 3) surge protectors for LED
- ✦ Class 2
- ✦ Very compact
- ✦ Plate mounting
- ✦ Screw terminal connection
- ✦ Status indicator
- ✦ Disconnection AC end of life
- ✦ EN 61643-11 compliance

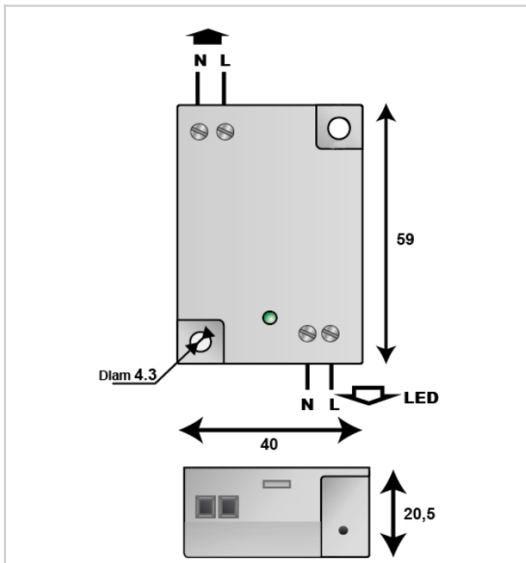

Electrical Characteristics			
SPD type	IEC	2+3	
Network	120-277 V Single-phase		
AC system	TT-TN		
Max. AC operating voltage	Uc	320 Vac	
Max. load current @25°C	IL	5 A	
Temporary Over Voltage (TOV) Characteristics - 5 sec. Without disconnection	UT	335 Vac withstand	
Temporary Over Voltage (TOV) Characteristics - 120 mn Without disconnection or with safety disconnection	UT	440 Vac disconnection	
Residual Current Leakage current to Ground	Ipe	None	
Nominal discharge current 15 x 8/20 µs impulses	In	5 kA	
Max. discharge current max. withstand @ 8/20 µs by pole	Imax	10 kA	
Total Maximum discharge current max. total withstand @ 8/20 µs	Imax Total	20 kA	
Withstand on Combination waveform IEC 61643-11 Class III test: 1.2/50µs - 8/20µs	Uoc	10 kV	
Withstand on overvoltages IEEE C62.41.1	10 kV / 10 kA		
Protection level @ In (8/20µs)	Up	1.8 kV	
Admissible short-circuit current	Iscrc	10 000 A	
Mechanical Characteristics			
Connection to Network	2 screw terminals opposite side in/out - wire 2.5mm² max.		
Mounting	On plate		
Housing material	Thermoplastic UL94 V-0		
Operating temperature	Tu	-40/+85°C	
Protection rating	IP20		
Failsafe mode	Disconnection and AC line cut-off		
Disconnection indicator	LED green OFF and AC network cut-off		
Voltage/operating indicator	Green Led ON		
Dimensions	See diagram		
Disconnectors			
Thermal disconnector	Internal		
Installation ground fault breaker	Type 'S' or delayed		
Standards			
Standards compliance	EN 61643-11 / IEC 61643-11		
Certification	TUV		
Part number			
832321			