

PAC25S-10-150

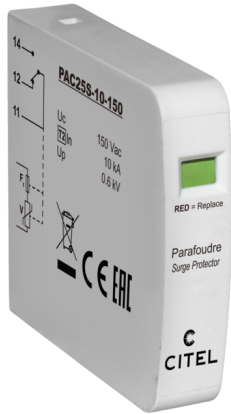

- ✦ Type 2 AC surge protector
- ✦ PCB mounting
- ✦ I<sub>max</sub>: 25 kA
- ✦ Remote signaling
- ✦ EN 50539-11 and IEC 61643-31 compliance\*

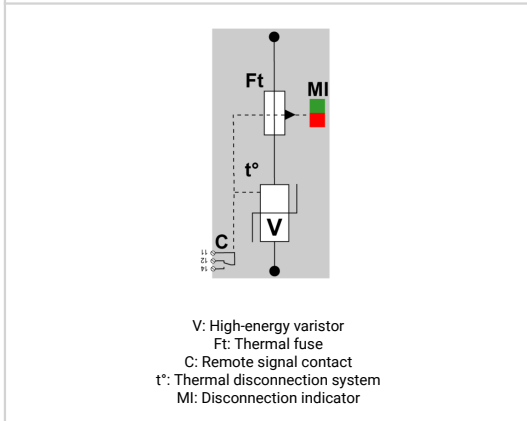
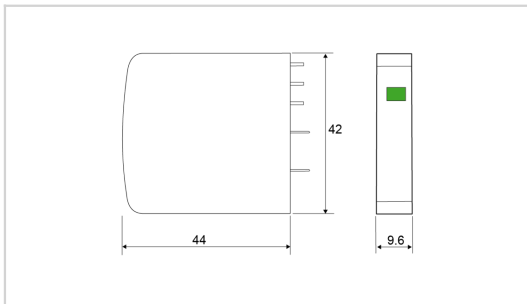

Electrical Characteristics		
SPD type	IEC	2
Max. AC operating voltage	U <sub>c</sub>	150 Vac
Nominal discharge current 15 x 8/20 μs impulses	I <sub>n</sub>	10 kA
Max. discharge current max. withstand @ 8/20 μs by pole	I <sub>max</sub>	25 kA
Protection level @ I <sub>n</sub> (8/20 μs)	U <sub>p</sub>	0.6 kV
Admissible short-circuit current	I <sub>sc</sub>	25 000 A
Mechanical Characteristics		
Connection to Network		Through soldering pins
Mounting		On Printed Circuit Board
Housing material		Thermoplastic UL94 V-0
Operating temperature	T <sub>u</sub>	-40/+85°C
Protection rating		IP20
Disconnection indicator		1 mechanical indicator
Remote signaling of disconnection		Output on changeover contact
Dimensions		9.6 mm
Weight		0.020 kg
Weight		0.051 kg
Disconnectors		
Thermal disconnector		Internal
Standards		
Standards compliance		EN 61643-11 / IEC 61643-11 *The standard cover devices. PPV/PAC series are components. Compliant when combined is an assembly.
Part number		
8711211		