

MLPC2-230L-V/ESP2

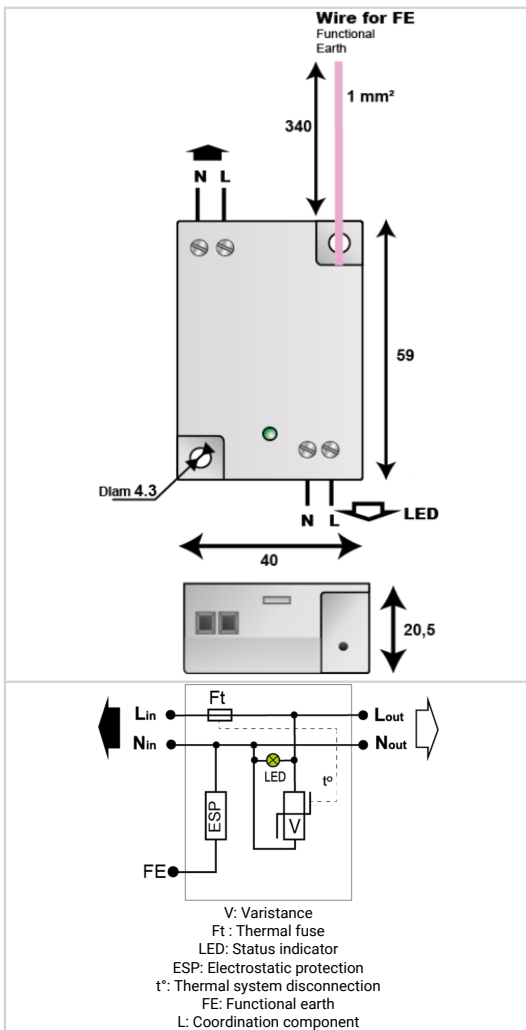

- Type 2 (or 3) Surge & Electrostatic protectors
- For Class II Led lighting
- Improved coordination with internal MOV
- Electrostatic protection included
- Comply class II safety rules
- Very compact
- Plate mounting
- Screw terminal connection
- Status indicator
- End of life AC Disconnection
- IEC 61643-11 and EN 61643-11 compliance



Electrical Characteristics		
SPD type	IEC	2+3
Network		220-240 V Single-phase
AC system		TT-TN
Max. AC operating voltage	Uc	320 Vac
Max. load current @25°C	IL	5 A
Temporary Over Voltage (TOV) Characteristics - 5 sec. Without disconnection	UT	335 Vac withstand
Temporary Over Voltage (TOV) Characteristics - 120 mn Without disconnection or with safety disconnection	UT	440 Vac disconnection
Residual Current	Ipe	None
Leakage current to Ground		
Nominal discharge current 15 x 8/20 µs impulses	In	5 kA
Max. discharge current max. withstand @ 8/20 µs by pole	Imax	10 kA
Total Maximum discharge current max. total withstand @ 8/20 µs	Imax Total	20 kA
Withstand on Combination waveform IEC 61643-11 Class III test: 1.2/50µs - 8/20µs	Uoc	10 kV
Withstand on overvoltages IEEE C62.41.1		10 kV / 10 kA
Protection level @ In (8/20µs)	Up	1.5 kV
Admissible short-circuit current	Iscrc	10 000 A
Electrostatic protection level	Uesp	0.5 kV
Electrostatic protection mode		N/Functional Earth
Mechanical Characteristics		
Connection to Network		2 screw terminals opposite side in/out - wire 2.5mm ² max.
Mounting		On plate
Housing material		Thermoplastic UL94 V-0
Operating temperature	Tu	-40/+85°C
Protection rating		IP20
Failsafe mode		Disconnection and AC line cut-off
Disconnection indicator		LED green OFF and AC network cut-off
Operating indicator		Green Led ON
Dimensions		See diagram
Weight		0.042 kg
Disconnectors		
Thermal disconnector		Internal
Installation ground fault breaker		Type 'S' or delayed
Standards		
Standards compliance		EN 61643-11 / IEC 61643-11
Certification		
Part number		
832227		