

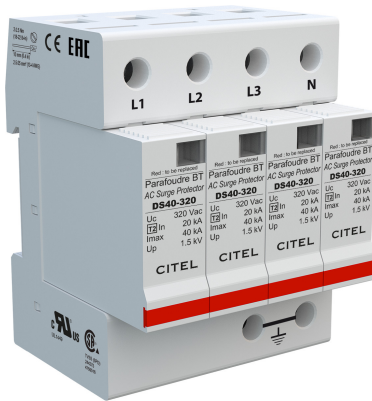

# CITEL

## Type 2 AC surge protector - 3-phase+N

### DS44-320



- › Discover our latest innovation : the [DAC50-40-320](#)
- › Type 2 AC Multipolar surge protector
- › In : 20 kA
- › I<sub>max</sub> total : 160 kA
- › Pluggable module for each phase
- › Remote signaling option
- › NF EN 61643-11, IEC 61643-11 compliance
- › UL1449 ed.5

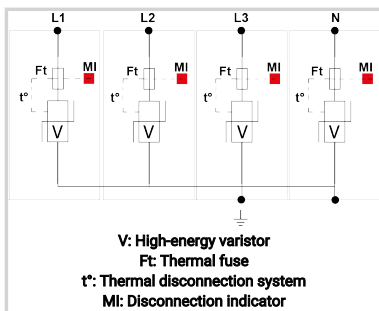

Electrical Characteristics		
SPD type	IEC	2
Network		230/400 V
AC system		TNS
Nominal line voltage	U <sub>n</sub>	230 Vac
Max. AC operating voltage	U <sub>c</sub>	320 Vac
Temporary Over Voltage (TOV) Characteristics - 5 sec. <i>Without disconnection</i>	UT	335 Vac withstand
Temporary Over Voltage (TOV) Characteristics - 120 mn <i>Without disconnection or with safety disconnection</i>	UT	440 Vac disconnection
Residual Current <i>Leakage current to Ground</i>	I <sub>pe</sub>	< 1 mA
Follow current	I <sub>f</sub>	None
Nominal discharge current <i>15 x 8/20 μs impulses</i>	I <sub>n</sub>	20 kA
Max. discharge current <i>max. withstand @ 8/20 μs by pole</i>	I <sub>max</sub>	40 kA
Total Maximum discharge current <i>max. total withstand @ 8/20 μs</i>	I <sub>max</sub> Total	160 kA
Connection mode(s)		L/PE and N/PE
Protection mode(s)		Common mode
Protection level <i>@ I<sub>n</sub> (8/20μs)</i>	U <sub>p</sub>	1.5 kV
Admissible short-circuit current	I <sub>scrr</sub>	25 000 A
Mechanical Characteristics		
Technology		MOV
SPD configuration		3-phase+Neutral
Connection to Network		By screw terminals: 2.5-25mm <sup>2</sup> / by bus
Format		Plug-in modular box
Mounting		Symmetrical rail 35 mm (EN 60715)
Housing material		Thermoplastic UL94 V-0
Operating temperature	T <sub>u</sub>	-40/+85°C
Protection rating		IP20
Failsafe mode		Disconnection from AC network
Disconnection indicator		1 mechanical indicator by pole
Spare module(s)		DSM40-320
Remote signaling of disconnection		option DS44S-320 : output on changeover contact
Dimensions		See diagram
Weight		0.356 kg
Disconnectors		
Thermal disconnector		Internal
Installation ground fault breaker		Type 'S' or delayed
Back-up protection device		Fuses type gG - 50 A
Standards		
Standards compliance		IEC 61643-11 / EN 61643-11 / UL1449 ed.5
Certification		cRUus
Part number		
<b>461902</b>		

